

Device Features

- Fully Qualified Bluetooth v2.1 + EDR specification System
- Best-in-class Bluetooth Radio with +8dBm Transmit Power and -90dBm Receive Sensitivity
- 64MIPS Kalimba DSP Co-processor
- 16-bit Internal Stereo CODEC - 95dB SNR for DAC
- Low-power 1.5V Operation, 1.8V to 3.6V I/O
- Integrated 1.5V and 1.8V Linear Regulators
- Integrated Switched-mode Regulator
- Integrated Battery Charger
- USB (TFBGA part only) and UART with Dual Port Bypass Mode to 4Mbits/s
- Enhanced Audibility and Noise Cancellation
- 68 Lead 8 x 8 x 0.9mm, 0.4mm pitch QFN Package
- 120 Ball 7 x 7 x 1mm, 0.5mm pitch TFBGA Package
- Support for IEEE 802.11 Coexistence
- Internal 8Mbit ROM
- RoHS Compliant

General Description

BlueCore5™-Multimedia ROM is a single-chip radio and baseband IC for Bluetooth 2.4GHz systems.

BlueCore5-Multimedia ROM contains 8Mbit internal ROM. When used with CSR's Bluetooth stack, it provides a fully compliant Bluetooth v2.1 + EDR specification system for data and voice.

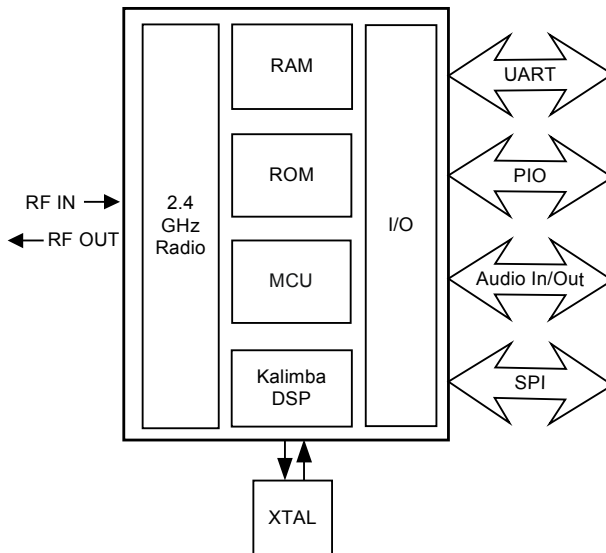

Figure: System Architecture

BlueCore5™-Multimedia ROM

Single Chip Bluetooth® v2.1 + EDR System

Advance Information

BC57F687A04

September 2007

Applications

- Wireless Headphones
- Wireless Speakers
- Mono Headsets with Echo and Noise Cancellation

BlueCore5-Multimedia ROM contains the Kalimba DSP co-processor with double the MIPS and double the memory of BlueCore3-Multimedia, supporting enhanced audio applications.

BlueCore5-Multimedia ROM is designed to reduce the number of external components required which ensures production costs are minimised.

The device incorporates auto-calibration and *built-in self-test* (BIST) routines to simplify development, type approval and production test.

To improve the performance of both Bluetooth and IEEE 802.11b/g co-located systems a wide range of co-existence features are available including a variety of hardware signalling: basic activity signalling, Intel WCS activity and channel signalling.

1 Device Details

Radio

- Common TX/RX terminal simplifies external matching; eliminates external antenna switch
- BIST minimises production test time

Transmitter

- +8dBm RF transmit power with level control from on-chip 6-bit DAC over a dynamic range >30dB
- Class 2 and Class 3 support without the need for an external power amplifier or TX/RX switch

Receiver

- Receiver sensitivity of -90dBm
- Integrated channel filters
- Digital demodulator for improved sensitivity and co-channel rejection
- Real-time digitised RSSI available on HCI interface
- Fast AGC for enhanced dynamic range

Synthesiser

- Fully integrated synthesiser requires no external VCO, varactor diode, resonator or loop filter
- Compatible with crystals between 8 and 32MHz (in multiples of 250kHz) or an external clock
- Accepts 7.68, 14.44, 15.36, 16.2, 16.8, 19.2, 19.44, 19.68, 19.8 and 38.4MHz TCXO frequencies for GSM and CDMA devices with sinusoidal or logic level signals

Baseband and Software

- Internal 8Mbit ROM
- Internal 48Kbyte RAM, allows full-speed data transfer, mixed voice/data and full piconet support
- Logic for forward error correction, header error control, access code correlation, CRC, demodulation, encryption bit stream generation, whitening and transmit pulse shaping
- Transcoders for A-law, μ -law and linear voice from host and A-law, μ -law and CVSD voice over air

Physical Interfaces

- Serial peripheral interface (SPI)* with clock speeds up to 64MHz in Master mode and 32MHz in Slave mode.
- USB (TFBGA package only) and UART interface with programmable data rate up to 3Mbits/s with an optional bypass mode
- Two LED drivers with faders

Kalimba DSP

- Very low power Kalimba DSP co-processor, 64MIPS, 24-bit (or 16-bit) fixed point core
- SBC decode takes approximately 4mW power consumption while streaming music
- Single-cycle MAC; 24 x 24-bit multiply and 56-bit accumulator
- 32-bit instruction word, dual 24-bit data memory
- 24Kbyte (6Kword) program RAM, 24Kbyte + 24Kbyte (8Kword + 8Kword) data RAM
- 64words x 32-bit program memory cache when executing from ROM

Stereo Audio CODEC

- 16-bit internal stereo CODEC
- ADC and DAC for stereo audio
- Integrated amplifiers for driving 16 Ω speakers; no need for external components
- Support for single-ended speaker termination and line output
- Integrated low-noise microphone bias
- ADC sample rates: 8kHz, 11.025kHz, 16kHz, 22.05kHz, 32kHz and 44.1kHz
- DAC sample rates: 8kHz, 11.025kHz, 12kHz, 16kHz, 22.05kHz, 24kHz, 32kHz, 44.1kHz and 48kHz

Auxiliary Features

- Crystal oscillator with built-in digital trimming
- Power management includes digital shutdown and wake up commands with an integrated low power oscillator for ultra-low power Park/Sniff/Hold mode
- Clock request output to control external clock
- On-chip regulator: 1.5V output from 1.8V to 2.7V input
- On-chip high-efficiency switched-mode regulator; 1.8V output from 2.7V to 4.4V input
- Device configuration with external EEPROM
- Power-on-reset cell detects low supply voltage
- 10-bit ADC and 8-bit DAC available to applications
- On-chip charger for lithium ion/polymer batteries

Bluetooth Stack

CSR's Bluetooth Protocol Stack runs on the on-chip MCU in a variety of configurations:

- Standard HCI (UART). USB available on TFBGA package
- Audio CODEC and echo-noise suppression or customer-specific algorithms running on the DSP

Package Options

- QFN 68 Lead, 8 x 8 x 0.9mm, 0.4mm pitch
- TFBGA 120 Ball, 7 x 7 x 1mm, 0.5mm pitch

2 Ordering Information

Interface Version	Package			Order Number
	Type	Size	Shipment Method	
UART	QFN 68 Lead (Pb free)	8 x 8 x 0.9mm, 0.4mm pitch	Tape and reel	BC57F687A04-IQF-E4 ^(a)
UART and USB	TFBGA 120 Ball (Pb free)	7 x 7 x 1mm, 0.5mm pitch	Tape and reel	BC57F687A04-ITN-E4 ^(a)

^(a) Until BC57F687A04 reaches **Production** status, order numbers for engineering samples apply. This is BC57F687A02-ES-IQB-E for the QFN package and BC57F687A02-ES-ITB-E for the TFBGA package. There is no minimum order quantity for engineering samples.

Note:

At **Production** status **Minimum Order Quantity** is 2kpcs taped and reeled.

To contact a CSR representative, email sales@csr.com or go to www.csr.com

Document History

Revision	Date	Change Reason
1	25 SEPT 07	Original Publication of this document. Based on CS-110315-PB To feedback on this document, email comments@csr.com